

PROJECT: _____
 CATALOG #: _____
 FIXTURE TYPE: _____
 NOTES: _____

UDD Dusk to Dawn Gen 3

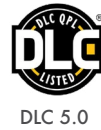

DLC 5.0

PERFORMANCE INFORMATION

SERIES NUMBER	WATT	LUMENS	CCT
UDD 65 G3 4K	45W	6,150	4000K
UDD 65 G3 5K	45W	6,200	5000K
UDD 90 G3 4K	65W	8,650	4000K
UDD 90 G3 5K	65W	8,800	5000K
UDD 125 G3 4K	90W	12,200	4000K
UDD 125 G3 5K	90W	12,200	5000K

The *UDD Dusk to Dawn Series Gen 3* area luminaire delivers unmatched light output and functionality that is ideal for a wide range of applications. This improved design includes an upgrade to SMD LED module to provide a higher lumen package, mounting plate for faster and easier wall mount installation, and new lens design to reduce glare. This upgraded luminaire delivers a wide uniform distribution with excellent vertical illumination for maximum light coverage. Twist-lock photocell is included with each luminaire. 3000K option is available.

APPLICATIONS

Barns, Perimeter Area Lighting, Loading Platforms, Boat Docks, Security Lighting, etc.

REPLACEMENT

175W MH – 250W MH

OPTIONS



Dark Bronze Arm Mount



Silver Arm Mount

ORDERING GUIDE

EXAMPLE: UDD 65 G3 5K S

Luminaire Type	Lumen Output	Generation	Voltage	CCT*	Finish	Options
UDD Dusk to Dawn	65 6,200 Lumens 90 8,800 Lumens 125 12,200 Lumens	G3	BLANK= 120-277V	4K 4000K 5K 5000K	BLANK= Dark Bronze S= Silver C** =Custom color	BLANK= Twist-lock Photocell UDD-AM= Silver Arm Mount Kit UDD-AMD= Dark Bronze Arm Mount Kit

*3000K option available. Please call sales.
 **For custom colors, please call sales.

Due to continuous product improvements, specification and/or equipment updates may change without notice.

SPECIFICATIONS

HOUSING

Die-cast aluminum.

AMBIENT TEMPERATURE

Suitable for use in -40°C to 40°C (-40°F to 104°F)

MOUNTING

Wall Mount Bracket included. Optional Arm Mount available.

EFFICACY

Up to 138 lumens per watt (see individual wattage data)

CCT AND CRI

4000K and 5000K CCT available; 70CRI

OPTICS

Acrylic lens

WARRANTY

10-year limited warranty. This product is eligible for the labor warranty. Comprehensive warranty terms can be located on www.slgus.com.

ELECTRICAL

Standard 120-277V input, 50/60Hz operation.
Standard NEMA Twist-Lock Photocell included.

ENERGY DATA

Power factor \geq 90%.

FINISH

Polyester Powder Coat in Dark Bronze and Silver Gray.
Custom colors are available.

CERTIFICATIONS

UL Listed for wet locations. Design Lights Consortium® (DLC) Standard 5.0 product. Not all versions of this product may be DLC qualified. Please visit www.slgus.com to confirm which versions are qualified.

DIMENSIONS

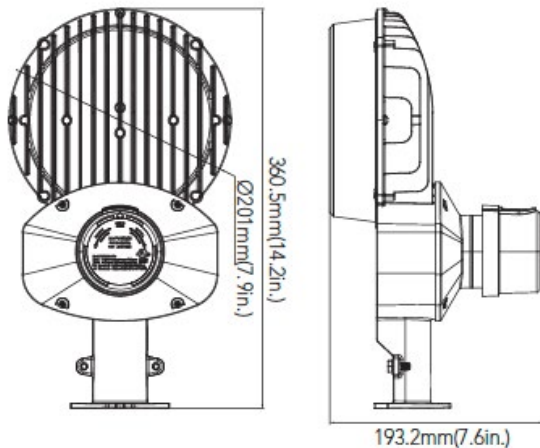

Weight

45W: 4.5393 LB
65W: 4.8038 LB
90W: 5.0287 LB

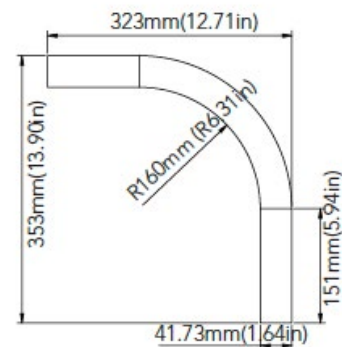

Arm Mount

Due to continuous product improvements, specification and/or equipment updates may change without notice.

REPLACEMENT DATA

Wattage	Replacement	Mounting Height
45W	175W MH	8'-15'
65W	200W MH	8'-15'
90W	250W MH	12'-20'

ELECTRICAL LOAD

Wattage	Current (A)			
	120V	208V	240V	277V
45W	0.38	0.22	0.19	0.16
65W	0.54	0.31	0.27	0.23
90W	0.75	0.43	0.38	0.32

Due to continuous product improvements, specification and/or equipment updates may change without notice.

PHOTOMETRIC

UDD 65 G3 5K
MOUNTING HEIGHT: 15FT

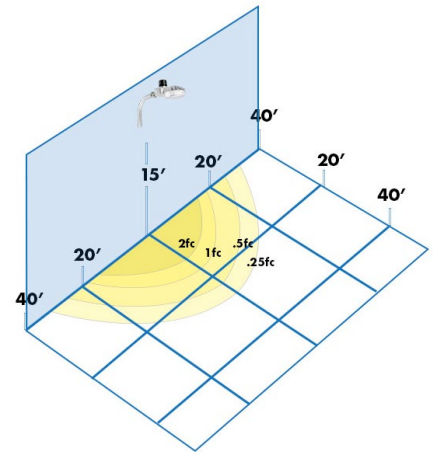
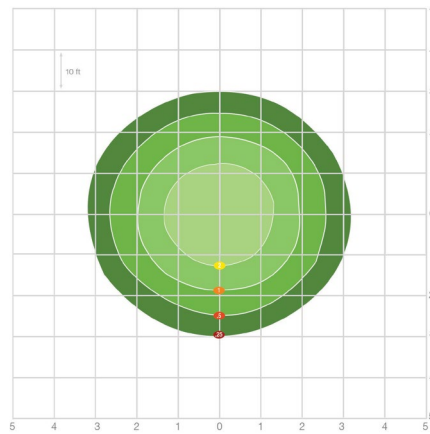

UDD 90 G3 5K
MOUNTING HEIGHT: 15FT

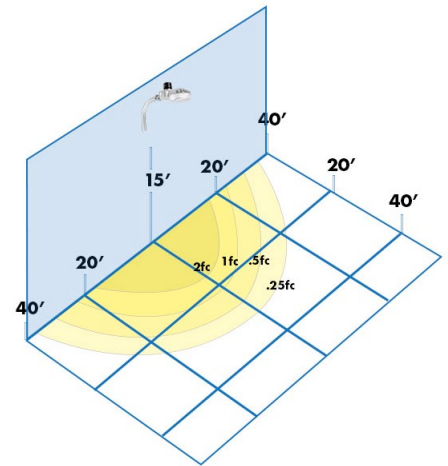
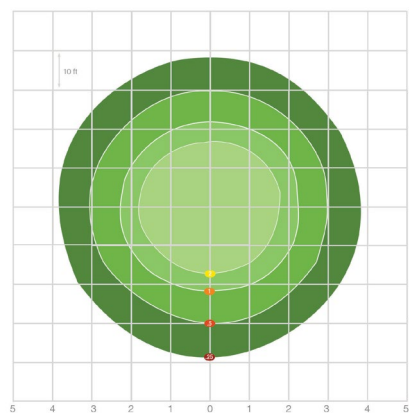

UDD 125 G3 5K
MOUNTING HEIGHT: 20FT

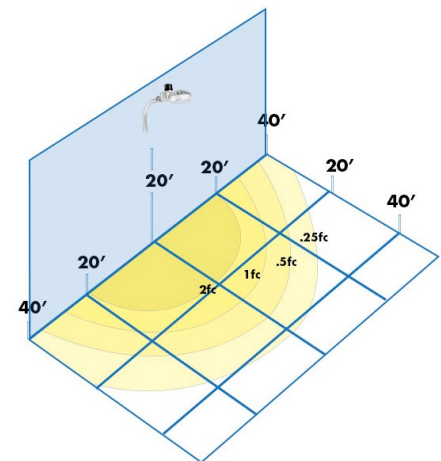
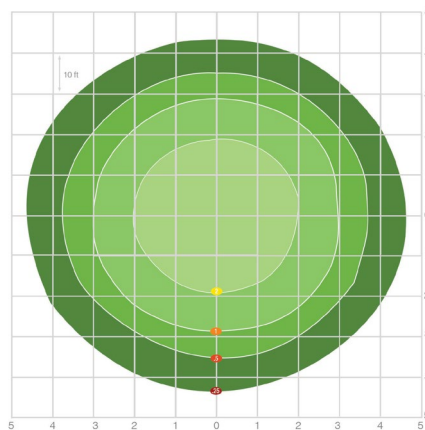

Due to continuous product improvements, specification and/or equipment updates may change without notice.